

PART NAME: KNOB SCALE: 1:1 DATE: 9/4/90 DR. BY HD

THIS DRAWING IS THE PROPERTY OF DAVIES MOLDING COMPANY, IS SUBMITTED SOLELY AS A DESIGN OR ENGINEERING PROJECT. WE ACCEPT NO RESPONSIBILITY WHATSOEVER FOR THE PRACTICAL APPLICATION OF THE PIECES MADE TO THIS DESIGN.



DESIGNERS & MANUFACTURERS OF KNOBS, HANDLES, CASES & CUSTOM PLASTIC COMPONENTS

P/N	3087-L
M NO. #	24
CAV.	3087
CORE	3087
CORE PLUG	3087
BUSHING	3087-L
EJCT.PIN	3087-L1
INSERT	I1695

T.O.# 5286

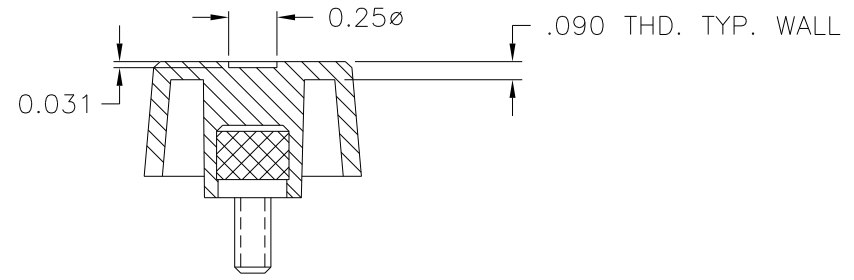
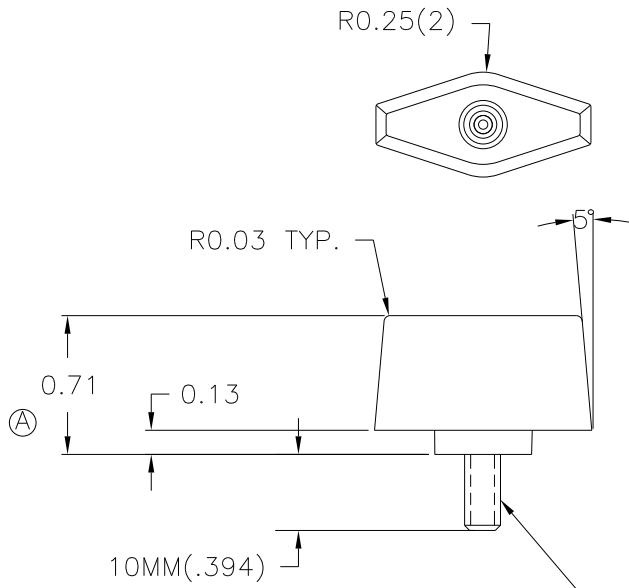

M5 X 0.8 X 10MM(.394) LG.- 6g FIT. I1695, STEEL, ZINC PLTD.

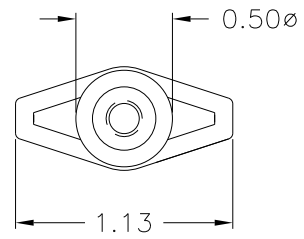

(C) MATERIAL: NYLON 6/6 (ZY2), (ZY6) OR ENGINEERING APPROVED EQUIVALENT
 (B) COLOR: BLACK

TOLERANCES: UNLESS OTHERWISE SPECIFIED	DO NOT SCALE DRAWING	C	ADDED ZY6	JAM	7/13/12
		B	ADDED MAT. CODE	DS	1/8/07
DECIMALS: X.XXX ± .005 X.XX ± .015	MM: X.XX ± 0.15MM X.X ± 0.4MM	A	O.A WAS 3/4, WAS 5/32	HD	6/7/95
		-	CAD/REDRAWN	HD	6/14/93
FRACTIONS ± 1/64	ANG. ± 1°	CHANGES			